

# CARATTERISTICHE TECNICHE

Technical features

Technische Eigenschaften

Caracteristiques techniques

características técnicas

# DOMI

## MELAMINICO • MELAMINE

**STRUTTURA:** pannello di particelle di legno con certificazione EPA-TSCA-CARB P2 a basse emissioni di formaldeide, nobilitato

**FRONTALI:** pannello di particelle di legno con certificazione EPA-TSCA-CARB P2 a basse emissioni di formaldeide, nobilitato

**STRUCTURE:** Wooden particle board EPA-TSCA-CARB P2 certified panel with low formaldehyde emission

**FRONT:** Wooden particle board EPA-TSCA-CARB P2 certified panel with low formaldehyde emission

## LACCATO • LACQUERED

**STRUTTURA:** pannello di particelle di legno con certificazione EPA-TSCA-CARB P2 a basse emissioni di formaldeide, nobilitato bianco laccato con vernici base acqua finitura satinata 36 colori lato esterno finitura lucida spazzolata a base solvente

**FRONTALI:** pannello di particelle di legno con certificazione EPA-TSCA-CARB P2 a basse emissioni di formaldeide, nobilitato bianco laccato con vernici base acqua finitura satinata 36 colori lato esterno finitura lucida spazzolata a base solvente

**STRUCTURE:** Wooden particle board EPA-TSCA-CARB P2 certified panel with low formaldehyde emission, white laminate, lacquered with water-borne paints, satin finish in 36 colours. External side in solvent-borne brushed glossy finish.

**FRONT:** Wooden particle board EPA-TSCA-CARB P2 certified panel with low formaldehyde emission, white laminate, lacquered with water-borne paints, satin finish in 36 colours. External side in solvent-borne brushed glossy finish.

## IMPIALLACCIATO • VENEERED

**STRUTTURA:** pannello di particelle di legno con certificazione EPA-TSCA-CARB P2 a basse emissioni di formaldeide, impiallacciato essenza di rovere finitura poro aperto- interno impiallacciato

**FRONTALI:** pannello di particelle di legno con certificazione EPA-TSCA-CARB P2 a basse emissioni di formaldeide, impiallacciato due lati essenza di rovere finitura poro aperto”

**CASSETTONI:** “Cassetto metallico ad estrazione totale con chiusura rallentata Blumotion antracite o bianco”

**MANIGLIA:** profilo in alluminio verniciato a polveri epossidiche

**RIPIANI:** vetro 6 mm.

**“PIEDI/VANI GIORNO TELAI ANTA”:** profilo in alluminio verniciato a polveri epossidiche

**STRUCTURE:** Wooden particle board EPA-TSCA-CARB P2 certified panel with low formaldehyde emission, external veneer in open-pore oak, internal wood veneer.

**FRONT:** Wooden particle board EPA-TSCA-CARB P2 certified panel with low formaldehyde emission, both sides in open-pore oak veneer.

**DRAWERS:** Total extraction metal drawer with soft closing mechanism. Anthracite or white Blumotion closing mechanism.

**HANDLE:** epoxy powder coated aluminium profile.

**SHELVES:** 6 mm width glass.

**OPEN-VIEW FEET/COMPARTMENTS:** epoxy-powder coated aluminium profile.

### Maniglia gola

C-profile handle

Griffe Hohlkehle

Poignée gorge

Tirador curvado

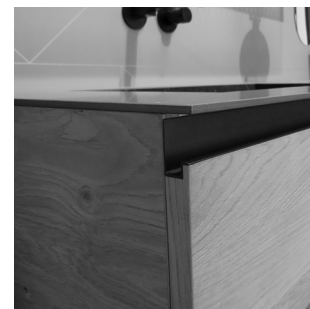

### Maniglia LAMA

LAMA handle

Griff LAMA

Poignée LAMA

Tirador tipo LAMA

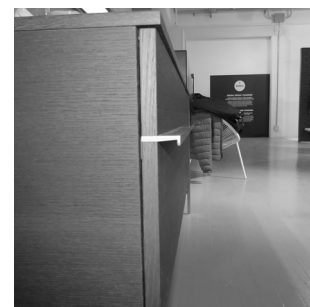

# MODULARITÀ

Modularity  
Möglichkeiten  
Modularité  
Módulos

# DOMI

## BASI SOPPESE

Hanging bases  
Hängeschränke  
Bases suspendues  
Bases colgantes

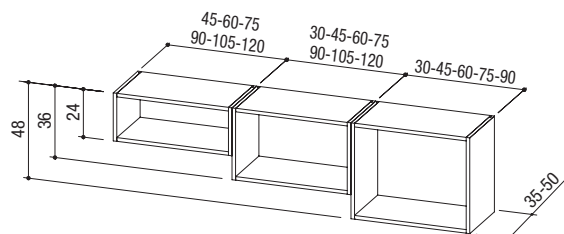

## COLONNE

Tall units  
Hochschränke  
Colonnes  
Columnas

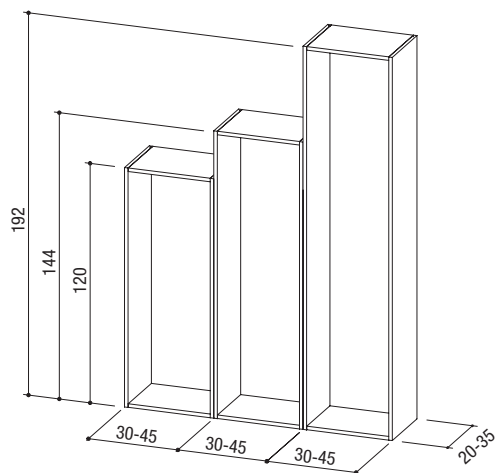

## COLONNE TELAIO VETRO

Glass frame columns  
Hochschränke Glasrahmen  
Colonnes cadre verre  
Columnas puerta de cristal

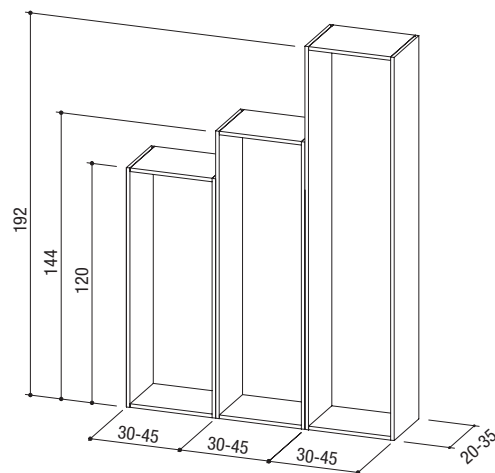

## PENSILI

Wall units  
Hängeschränke  
Éléments hauts  
Colgante

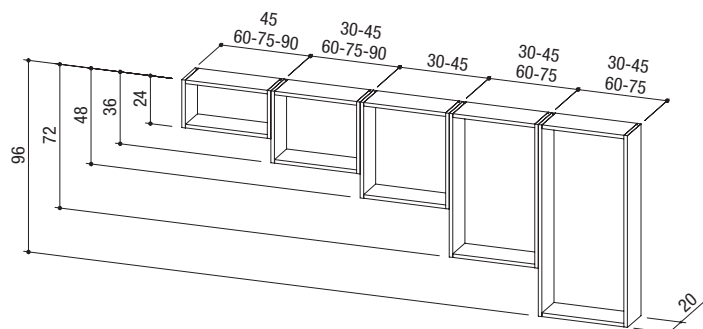

## SCARPIERE

Shoe-cabinets  
Schuhschränke  
Meuble à chaussures  
Muebles zapatero

