

MAJOR

BASI BASE UNITS



APERTURA: tramite prensilità sulla parte superiore del frontale che sporge rispetto alla scocca

FRONTALI: pannelli di particelle di legno certificati CARB-02 sp 22 mm rivestiti con nobilitazione melaminica, laccati o impiallacciati legno e verniciati; bordatura poliuretanica idrorepellente.

FRONTALI GRES: gres sp 6 mm incollato a pannello di particelle di legno certificato CARB-02 sp 14 mm rivestito con nobilitazione melaminica; bordatura poliuretanica idrorepellente.

OPENING: grip on the top part of the front protruding from the structure

FRONTS: CARB-02-certified 22 mm thick particleboard panels which have a melamine coating, are lacquered or have a painted wood veneer; water-repellent polyurethane edging.

STONEWARE FRONTS: 6 mm thick stoneware bonded to CARB-02-certified 14 mm thick particleboard panels with a melamine coating; water-repellent polyurethane edging.

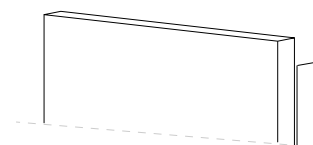
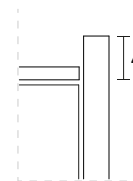

FIANCHI DI FINITURA FINISHING SIDES



La composizione va sempre completata lateralmente con i fianchi di finitura.

Realizzati con pannelli di particelle di legno certificati CARB-02 sp 22 mm rivestiti con nobilitazione melaminica, laccati o impiallacciati legno e verniciati; bordatura poliuretanica idrorepellente.

The composition must always be completed with finishing sides.

Made with CARB-02-certified 22 mm thick particleboard panels which have a melamine coating, are lacquered or have a painted wood veneer; water-repellent polyurethane edging.

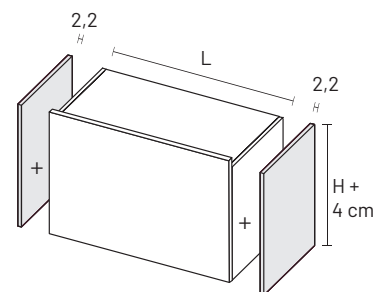

ELEMENTI BIFACCIALI DOUBLE-SIDED UNITS



Utilizzo di basi specifiche che possono essere rese bifacciali completandole con un pannello di finitura applicato sul retro della composizione.

Realizzati con pannelli di particelle di legno certificati CARB-02 sp 22 mm rivestiti con nobilitazione melaminica, laccati o impiallacciati legno e verniciati; bordatura poliuretanica idrorepellente.

Use of specific base units that can be made double-sided by applying a finishing panel to the back of the composition.

Made with CARB-02-certified 22 mm thick particleboard panels which have a melamine coating, are lacquered or have a painted wood veneer; water-repellent polyurethane edging.

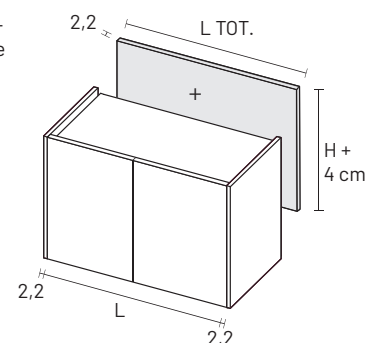

MAJOR

BASI BASE UNITS

